



FRNSW compatible Storz hose connections

1 Purpose

This technical information sheet details Fire and Rescue NSW (FRNSW) requirements for hose connections installed on any new or upgraded fire hydrant and fire sprinkler system.

2 Scope

This technical information sheet details:

- (a) the regulations and standards applicable to hose connections
- (b) design, specification and installation requirements for hose connections to be compatible with FRNSW equipment
- (c) requirements for independent testing and certification of hose connections
- (d) the process for verifying compliance of hose connections and rectifying actions to be taken when non-compliant hose connections are identified.

3 Application

This document applies to 65 mm hose connections on any new or upgraded fire hydrant or fire sprinkler system installed in any building, facility or site within NSW.

Note: This document does not apply to large bore hose connections (e.g. 150 mm).

FRNSW compatible hose connections are required on all fire brigade booster inlets, feed fire hydrant outlets and attack fire hydrant outlets.

FRNSW considers the hose connection part of the fixed system as relating to *Australian Standard AS 2419.1-2005*¹ and the *Plumbing Code of Australia*. Hose connections must be checked during compliance inspections and tested as part of system commissioning.

This document is intended to be used by fire protection installers, fire engineers, hydraulic consultants, certifiers, local government authorities and regulatory authorities.

4 Background

FRNSW historically used fire hoses with fire brigade thread (FBT) couplings. FBT was based on the London 'V' thread which is sometimes referred to as NSW 'V' thread. Current fire hoses are fitted with Storz 65 mm hermaphrodite couplings to standard *NEN 3374 Fire fighting equipment – Fire hose couplings and ancillary equipment (NEN 3374:1971)*.

In 2008 the FRNSW Commissioner determined that Storz hose connections were to be fitted to new fire hydrant systems as FBT was no longer used on fire brigade equipment. An 'FBT-Storz adaptor' as specified by FRNSW was to be fitted onto the FBT inlets and outlets of fire hydrant and fire sprinkler systems.

However, competition and an unregulated market has resulted in cheap and low quality Storz which do not meet any standard and are not suitable for firefighting. Generally, only fire equipment manufacturers produce compliant hose connections to firefighting standard.

¹ AS 2419.1-2005 *Fire hydrant installations: System design, installation and commissioning*

*NEN 3374:1971*² specifies the use of wrought (i.e. forged) aluminium, or 'cast brass' for salt water proof designs. Storz hose connections made from cast aluminium do not comply with *NEN 3374:1971* and are specifically prohibited by Australian Standards.

Cast aluminium is up to three times weaker than forged aluminium. Cast aluminium Storz can fail catastrophically at firefighting pressures, and result in life safety risks including the connection being unusable and impacting on firefighting operations (see Figure 1). Cast aluminium Storz is only used in industrial applications up to 1,000 kPa operating pressure.

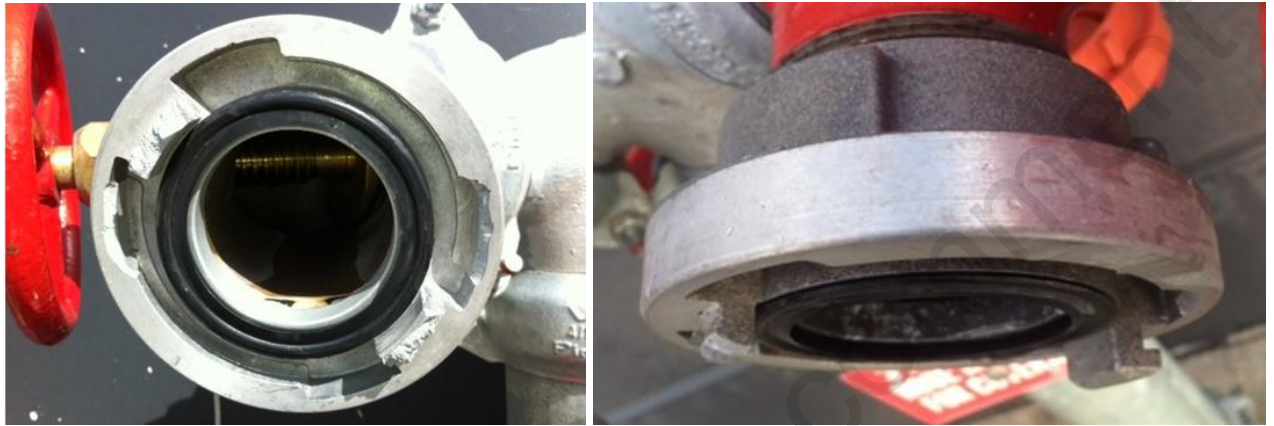

Figure 1 Examples of failure of cast aluminium Storz hose connections

5 Regulations and standards

Clause E1.3 of the *NCC*³ requires a fire hydrant system serving a building to be installed in accordance with *AS 2419.1-2005*.

Clauses 3.1 and 8.5.11.1 of *AS 2419.1-2005* states that hose connections shall be compatible with local fire brigade equipment.

Appendix E1 and E2 of *AS 2419.1-2005* states that FRNSW use both 64 mm x 4.88 mm pitch (2¹/₂ x 5¹/₅ TPI i.e. teeth per inch) FBT and Storz hermaphrodite hose couplings.

Note: FRNSW do not use FBT hose couplings on fire hoses. Adaptors are carried on fire appliances for use on systems that have FBT inlets and outlets.

5.1 Fire brigade boosters

Clauses 1.2 of *AS 2419.3-2012*⁴ specify fire brigade booster inlet connections are to be fitted with hose connections that comply with local fire brigade requirements.

Appendix B of *AS 2419.3-2012* states FRNSW use '*NEN 3374*' Storz hermaphrodite hose couplings.

Table 2.1 of *AS 2419.3-2012* states Storz fire brigade booster inlet connections can be either aluminium or copper alloy.

Clause 3.5 of *AS 2419.3-2012* states the Storz hose connections must be forged or hot-pressed, and that cast hose connections are not permitted.

Clause 4.4.3 of *AS 2118.1-1999*⁵ requires an automatic fire sprinkler system to be fitted with a fire brigade booster connection (i.e. *AS 2419.3-2012*). The sprinkler booster connection must also therefore be fitted with hose connections that comply with local fire brigade requirements.

² *NEN 3374:1971 Fire fighting equipment – Fire hose couplings and ancillary equipment*

³ *National Construction Code Series Volume One, Building Code of Australia Class 2 to Class 9 Buildings*

⁴ *AS 2419.3-2012 Fire hydrant installations: Fire brigade booster connections*

⁵ *AS 2118.1-1999 Automatic fire sprinkler systems: General systems*

5.2 Fire hydrant valves

Clause 1.2 of AS 2419.2-2009⁶ states the method of attachment of hose connections fitted to fire hydrant valves shall comply with local fire brigade requirements.

Clause 3.4 of AS 2419.2-2009 states hose connections fitted to fire hydrant valves shall comply with local fire brigade specifications. Also, where used Storz hose connections shall be manufactured in copper alloy or aluminium using forged processes.

Appendix B2 of AS 2419.2-2009 states that 64 mm × 4.88 mm pitch (i.e. FBT) and Storz hermaphrodite hose couplings are used within Australia.

Note: FRNSW do not use FBT hose couplings on fire hoses.

6 Storz hose connections

6.1 Booster inlets

6.1.1 Hose connections on fire brigade booster inlets (i.e. AS 2419.3⁷) are to be fitted with Storz 65 mm 'permanent pressure coupling' complying with NEN 3374:1971, having 2½ inch British standard pipe (BSP) thread to DIN ISO 228-1⁸ (i.e. parallel BSP).

Note: NEN 3374:1971 compliant Storz are made from aluminium alloy EN AW6082 or from copper alloy C85710 of DIN EN 1982⁹.

6.2 Hydrant outlets

6.2.1 Hose connections on fire hydrant valve outlets (i.e. AS 2419.2) are to be either:

- (a) an FBT-Storz adapter complying with FRNSW specifications and fitted onto a fire hydrant valve outlet having male FBT, or
- (b) fitted with Storz 65 mm 'permanent pressure coupling' complying with NEN 3374:1971, having 2½ inch BSP thread to DIN ISO 228-1 (i.e. parallel BSP).

Note: NEN 3374:1971 compliant Storz are made from aluminium alloy EN AW6082 or from copper alloy C85710 of DIN EN 1982.

6.3 The FBT-Storz adapter

6.3.1 The FBT-Storz adapter must satisfy the requirements of this document to be compatible with FRNSW equipment and specifications. These requirements specify the FBT-Storz adaptor be equivalent in fit, form and function to DIN and NEN norms for firefighting Storz.

Note: There is no current standard applying specifically to the FBT-Storz adaptor.

6.3.2 The FBT-Storz adapter is to have the following fit:

- (a) a Storz 65 mm cam ring connection which conforms to NEN 3374:1971, Section 3 *Dimensions and Coding*, Part No. 5, with thread section (i.e. dimensions) exempted
- (b) female 2½ × 5⅓ TPI Whitworth form thread (i.e. FBT) to fit the opposing male FBT on the fire hydrant valve (refer to Figure 2 inset for FBT thread specifications)
- (c) a delivery sealing ring for pressure that conforms to NEN 3374:1971, Section 3, *Dimensions and Coding*, Part No. 36
- (d) a gasket (i.e. flat sealing ring) that conforms to NEN 3374:1971, Section 3, *Dimensions and Coding*, Part No. 49.

⁶ AS 2419.2-2009 *Fire hydrant installations: Fire hydrant valves*

⁷ AS 2419.3-2012 *Fire hydrant installations: Fire brigade booster connections*

⁸ DIN ISO 228 *Pipe threads where pressure-tight joints are not made on the threads -- Part 1: Dimensions, tolerances and designation (2003)*

⁹ DIN EN 1982 *Copper and copper alloys - Ingots and castings (2017)*

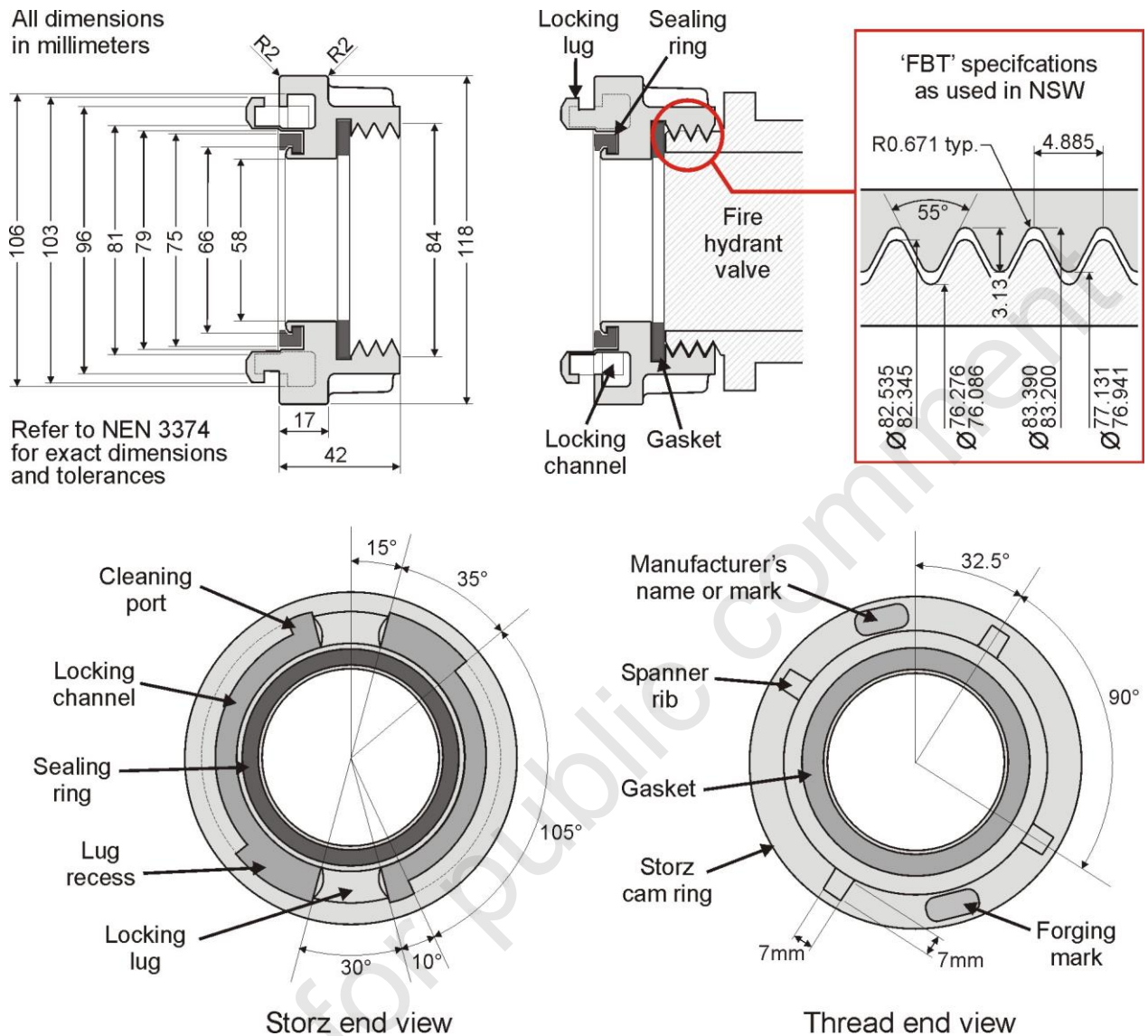

Figure 2 FBT-Storz adapter

6.3.3 The FBT-Storz adapter is to have the following form:

- (a) be forged aluminium alloy EN AW6082 (AlSi1MgMn) to composition *DIN EN 573-3*¹⁰, unless being used in salt water proof designs

Note: EN AW 6082 is the current AlMgSi1 F28 alloy as specified by *DIN 1725 Sheet* ¹¹. Copper alloy C85710 of *DIN EN 1982*¹² may be used in salt water proof designs.

- (b) be machined with tolerances where specified by *NEN 3374:1971*, and as per *DIN ISO 2768-m* for dimensions that are specified without tolerance
- (c) be fitted with a delivery sealing ring suitable for pressure operation made from nitrile rubber with a hardness of 60 ± 5 Shore A according to *DIN ISO 7619-1*¹³
- (d) be fitted with a gasket (flat sealing ring) made from nitrile rubber with a hardness of 80 ± 5 Shore A according to *DIN ISO 7619-1*.

¹⁰ *DIN EN 573-3 Aluminium and aluminium alloys - Chemical composition and form of wrought products Part 3: Chemical composition and form of products (2013)*

¹¹ *DIN 1725-1 Aluminium Alloys – Wrought Alloys (1983, superseded)*

¹² *DIN EN 1982 Copper and copper alloys - Ingots and castings (2017)*

¹³ *DIN ISO 7619-1 Rubber, vulcanized or thermoplastic - Determination of indentation hardness - Part 1: Durometer method (2010)*

Uncontrolled if printed, copied or emailed, Always check the Fire & Rescue NSW website for the most recent version

6.3.4 The FBT-Storz adapter is to have the following functionality:

- (a) be single piece aluminium which is forged to *DIN EN 586-2*¹⁴ and suitable for pressure application (i.e. temper designation T6 as per *EN 515*¹⁵, with minimum Brinell hardness of 90 HB and tensile strength of 310 MPa)

Note: Copper alloy (i.e. diecast brass) is to have a minimum Brinell hardness of 60 HB and tensile strength of 300 MPa.

- (b) have a rated operating pressure of 1,600 kPa (i.e. 'Pressure Nominal' of PN16)

- (c) have a minimum test pressure of 2,400 kPa and be able to withstand any leak for a minimum of two minutes

- (d) have a connection/disconnection torque range of 3 Nm to 8 Nm.

6.3.5 All firefighting equipment manufactured under European standard are subject to certification under *Pressure Equipment Directive (PED) 2014/68/EU*.

Note: The FBT-Storz adaptor is to be able to pass such certification.

6.3.6 The FBT-Storz adapter must be permanently marked in raised lettering with:

- the manufacturer's name, trademark or logo
- the forger's registered forging mark.

Note: Any marking of the FBT-Storz adapter as being forged which is not a properly registered forging mark by the forger may not be accepted.

6.4 Installation

6.4.1 All Storz hose connections must be tightly and securely fitted with the gasket (flat sealing ring) in the female portion of the connection providing all thread locking resistance.

7 Protective end cap and retaining chain/wire

7.1 Each hose connection must be provided with a protective blanking cap which is securely attached to the fixed system by a retaining chain or wire (refer to Figure 3).

7.2 The protective end cap must be fully compatible with the hose connection including materials compatibility (e.g. aluminium alloy, inert polymer).

7.3 The protective end cap must have a 3 mm pressure relief hole.

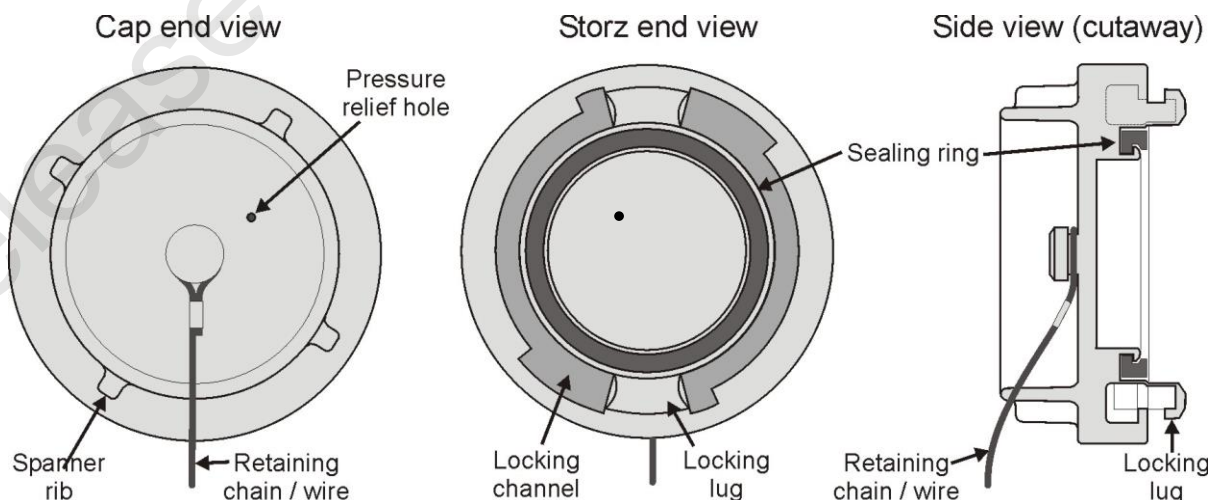

Figure 3 Storz protective end cap

¹⁴ *DIN EN 586-2 Aluminium and aluminium alloy forgings - Mechanical properties and additional properties (1994)*

¹⁵ *DIN EN 515, Aluminium and aluminium alloys - Wrought products - Temper designations (2017)*

- 7.4 The retaining chain or wire may be an S-hook and chain, S-hook and stainless-steel wire cable, or stainless-steel wire cable crimped with a ferrule, as per part 3.10 of AS 2419.2-2009¹⁶ and part 3.9 of AS 2419.3-2012¹⁷.
- Note:** FRNSW recommends using nylon coated stainless steel wire cable crimped by ferrule. The S-hook is prone to being easily damaged and the end cap being lost.
- 7.5 The free length of the retaining chain or wire must allow easy removal of the protective end cap so the end cap does not obstruct any hose connection when connecting a fire hose.
- Note:** FRNSW recommends a free length of approximately 200 mm longer than the distance from the anchor point to the fitted position (refer to Figure 4).

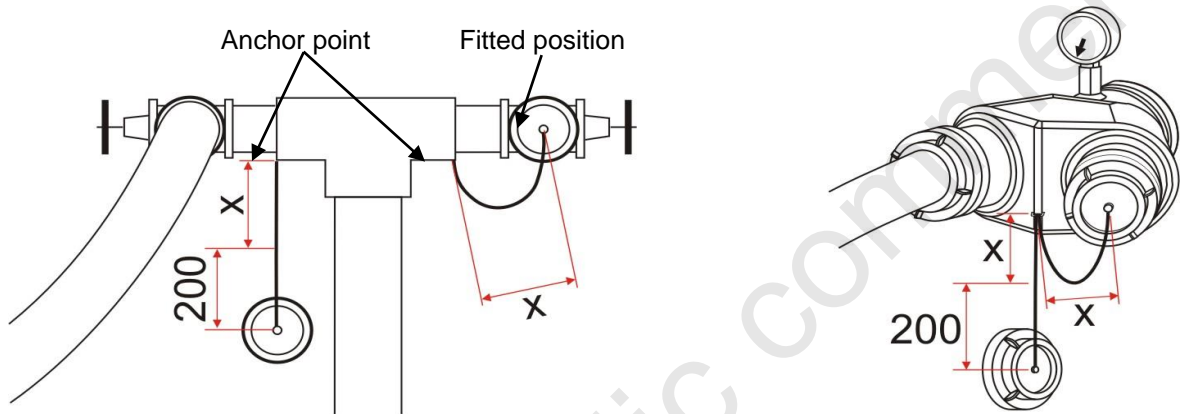

Figure 4 Example of free length required of retaining chain/wire

8 Independent testing, certification and quality assurance

- 8.1 Hose connectors must demonstrate compliance through certification from an independent Conformity Assessment Body accredited for product certification, accredited by either:
- the Joint Accreditation System of Australia and New Zealand (JAS-ANZ)
 - a signatory to the International Accreditation Forum Multilateral Recognition Arrangement (IAF MLA).
- 8.2 Any testing demonstrating compliance must be performed by a facility accredited by either:
- a National Association of Testing Authorities (NATA) accredited facility.
 - a facility accredited by a signatory to the International Laboratory Accreditation Cooperation.
- 8.3 The test results must include values and data; pass or fail results alone will not be accepted.
- Note:** The results should identify dimensions, tolerances, material composition, manufacturing process (i.e. forging and temper) and pressure testing (i.e. PN rating) all conform to nominated standards.
- 8.4 A continuing process of batch testing and auditing should be carried out by the Conformity Assessment Body as part of a continual certification process.
- 8.5 If independent certification is supplied from the manufacturer or supplier, and the relevant authority considers such certification to be false or incorrect, the authority may conduct its own independent testing to verify the certification claims.

Note: A 'letter of conformity' from the manufacturer or supplier that is not able to be validated through independent testing and certification may not be accepted.

¹⁶ AS 2419.2-2009 Fire hydrant installations: Fire hydrant valves

¹⁷ AS 2419.3-2012 Fire hydrant installations: Fire brigade booster connections

9 Determining compliance

- 9.1 FRNSW document *Inspecting hose connections on installed fire systems* should be used for guidance on determining whether a hose connection is compliant or not.
- 9.2 The fire protection installer is to ensure only compliant hose connections are purchased from a reputable supplier and installed.
- Note:** The fire protection installer should ensure the manufacturer or supplier is able to provide independent certification of their product (refer to section 8).
- 9.3 The fire protection installer (i.e. purchaser) should provide information from this document at the time of making the enquiry or order, as per Appendix C of AS 2419.2-2009¹⁸ and AS 2419.3-2012¹⁹.
- Note:** Generally, only manufacturers and suppliers of firefighting equipment will produce compliant hose connections meeting the required firefighting standard.
- 9.4 Hose connections must be checked as part of system commissioning and certification:
- (a) The fire protection installer is to check hose connections are compliant before issuing documentation for a fire safety certificate.
 - (b) The principal certifying authority is to check hose connections are compliant when determining any application for occupation certificate.
- 9.5 A fire protection installer should check hose connections are compliant when inspecting a premises for the purpose of a fire safety statement.
- 9.6 A regulatory authority should check hose connections are compliant when inspecting a premises for a fire safety compliance inspection.
- 9.7 FRNSW may check hose connections are compliant when inspecting premises for fire safety compliance.
- Note:** FRNSW may issue an Order to have all non-complying hose connections replaced, especially if cast aluminium Storz has been installed instead of forged.
- 9.8 A regulatory authority may take action against any fire protection installer who knowingly installs, or any certifier who knowingly certifies, non-compliant hose connections.
- Note:** The premises owner has a reasonable expectation that only compliant hose connections have been purchased, installed and certified.

10 Contact us

For further information contact the Fire Safety Branch on (02) 9742 7434 or email firesafety@fire.nsw.gov.au.

¹⁸ AS 2419.2-2009 *Fire hydrant installations: Fire hydrant valves*

¹⁹ AS 2419.3-2012 *Fire hydrant installations: Fire brigade booster connections*